

TOTAL BRAND LICENSING

Production Information Double Page Spread Advertisements 2017

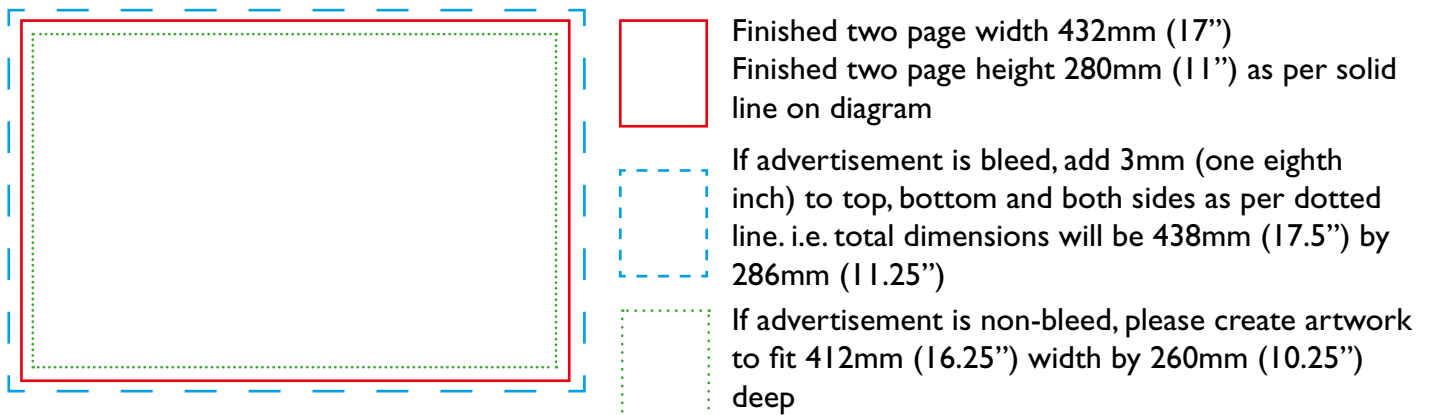

Advertisers should provide artwork in digital format. Artwork should be in one of the following formats: **Press-ready PDF, Adobe Illustrator file, Adobe Photoshop, JPG, TIFF or EPS.**

All graphics should be produced high-resolution (minimum 300dpi) and should be in a CMYK format.

All fonts used should be embedded.

MATERIAL DELIVERY

Via Email:

francesca@totallicensing.com

Via your FTP or a third party FTP:

For large files, you can provide us with details of your ftp for us to download the material, or if preferred, a third-party FTP (eg wetransfer.com, hightail.com etc) and upload your material so that we can access it.

MATERIAL DEADLINES

Winter 2017..... 5 Jan 2017

Spring 2017..... 22 Feb 2017

Summer 2017..... 21 April 2017

Autumn/Fall 2017..... 5 Sept 2017